

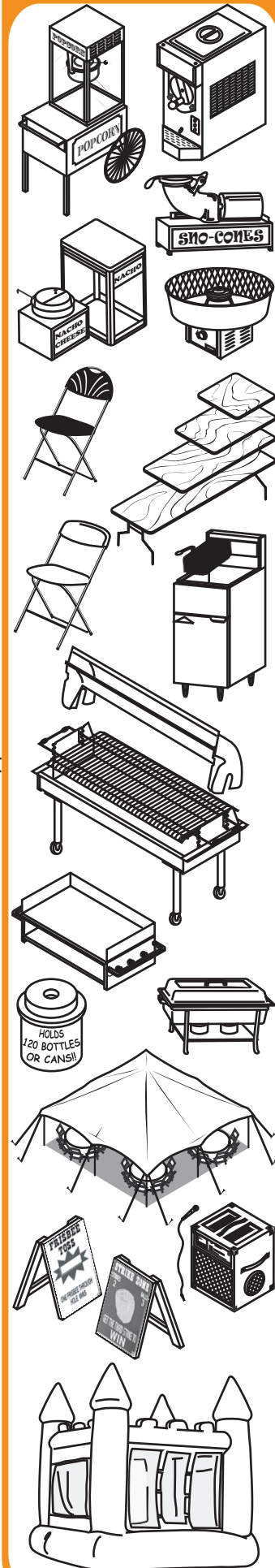

FAMILY REUNIONS

1. Choose a leader and form a reunion committee. Decide what type of reunion you will be having, e.g. a one day event such as a picnic / barbeque or a longer weekend event. Delegate responsibilities to your committee members including securing locations, budget planning, organizing activities, purchasing and preparing food, etc.
2. If holding your event at a public location make sure to secure any necessary permits and facility reservations for your event before announcing the final date.
3. Family members should be sent a "Save the Date" card about 6-10 months prior. Invitations should go out 2-6 months before the event and reminders 1 month before.
4. Overhead protection during your event is a must for young and old alike, and will be appreciated rain or shine.
5. Setting up a family website is a good way to keep everyone up to date. Do a pre-reunion survey to find out major accomplishments, new children's names and birthdays, major anniversaries, birthdays or milestones. Check out www.reunionsmag.com for some survey ideas.
6. When decorating for your reunion include LOTS of family photos. A video projector and large screen is a great way to show old family movies and pictures. Websites such as www.fotolog.com are a great way to share photos as a group.
7. Take lots and lots of pictures at your reunion, maybe even hire a professional photographer if your budget allows.
8. Having some custom tee-shirts, hats, coffee mugs or key chains made is a fun way commemorate your event and give everyone a memento of the reunion.
9. Setup a crew ahead of time to help during the reunion. Planning a family reunion can be alot of work and now it's your time to sit back, relax and enjoy yourself along with your family.
10. Please be conscious of alcohol consumption during your event and take any precautions to ensure everyone has a safe and enjoyable time.



EVENT EQUIPMENT DIRECT

TABLES & CHAIRS ● TENTS & CANOPIES ● KIDS FUN JUMPS ● CATERING EQUIPMENT
 POPCORN & COTTON CANDY MACHINES ● AUDIO VISUAL EQUIPMENT
 PERFORMANCE STAGES ● PIPE AND DRAPE ● CROWD CONTROL BARRICADES